

This F-Mount lens is for large formats. A V48-Mount for more flexibility on request. Optimized for shorter distances, magnifications around 1:10. The low field of curvature makes the lens the ideal choice where a compact lens inquires large field of view. The robust lenses are for quality control as well as for medical applications. We also offer a version optimized for long working distances.

Key features

- F-Mount
- 43.2 mm image circle
- optimized for short working distances
- 400-1000 nm broadband AR-coating

Applications

- Quality control
- Code reader
- Web inspection
- Factory automation

Technical specifications

Type	-0006
ID	1071609
Interface	F-Mount
Focal length [mm]	28
F/# range	F/2.8 ... F/22
Numerical aperture	0.18
Max. sensor size [mm]	43.2
Max. angle of view [°]	76
Rec. magnification range	-0.1 ... -0.03
Rec. working distance range [mm]	265 ... 939
Max. mechanical focus travel [mm]	-
Filter thread [mm]	M62 x 0.75
Storage temperature [°C]	-25 ... +70
Net. weight [g]	517
Additional info	-
f'eff [mm]	28.77
SF [mm]	19.96
S'F' [mm]	37.98
HH' [mm]	56.58
β'P	3.64
SEP [mm]	27.85
S'AP [mm]	-66.86
Σd [mm]	96.09

MTF charts

Spectrum name	VIS					
Wavelengths [nm]	425	475	525	575	625	675
Rel. weights [%]	8	16	23	22	19	13

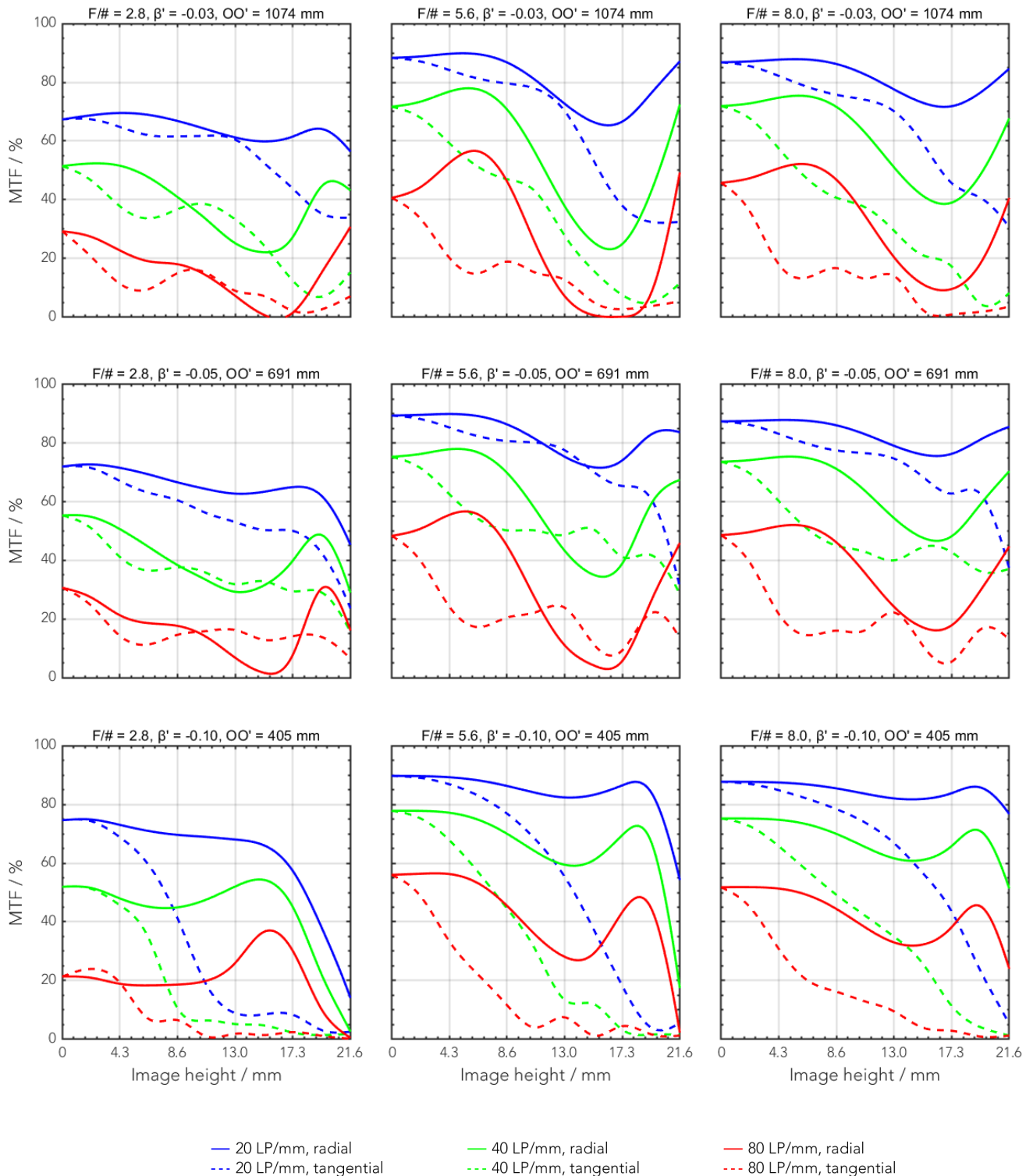

Rel. illumination vs. image height

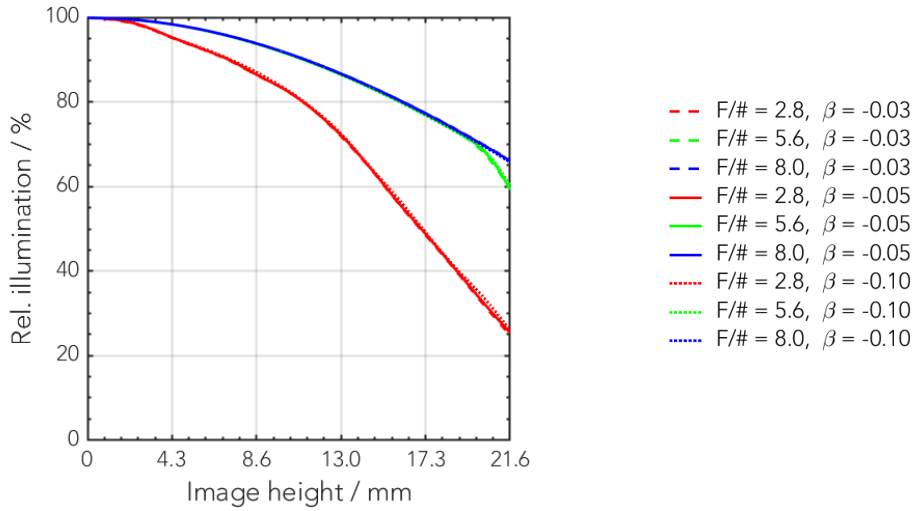

Distortion vs. image height

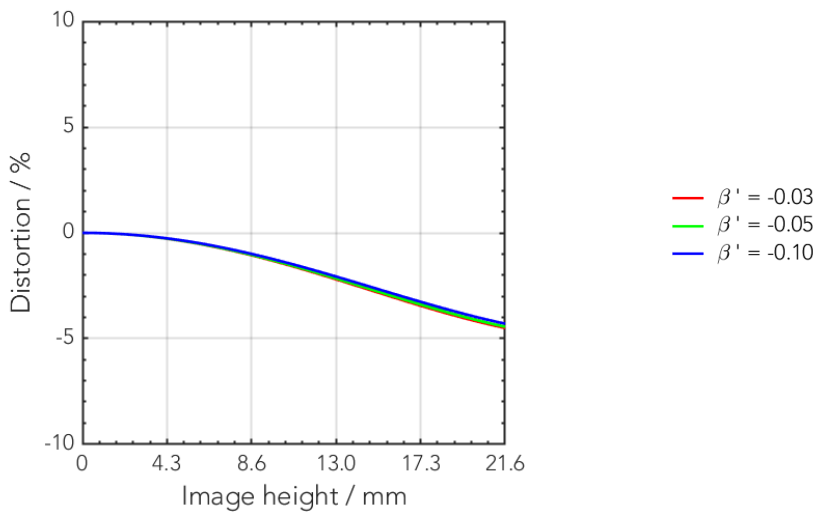

Transmittance vs. wavelength

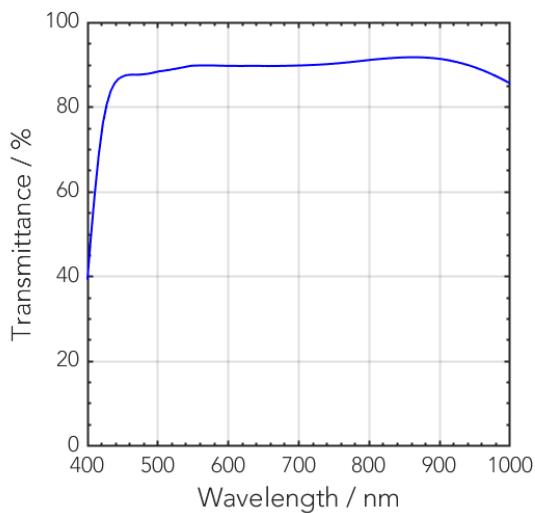

Technical drawings

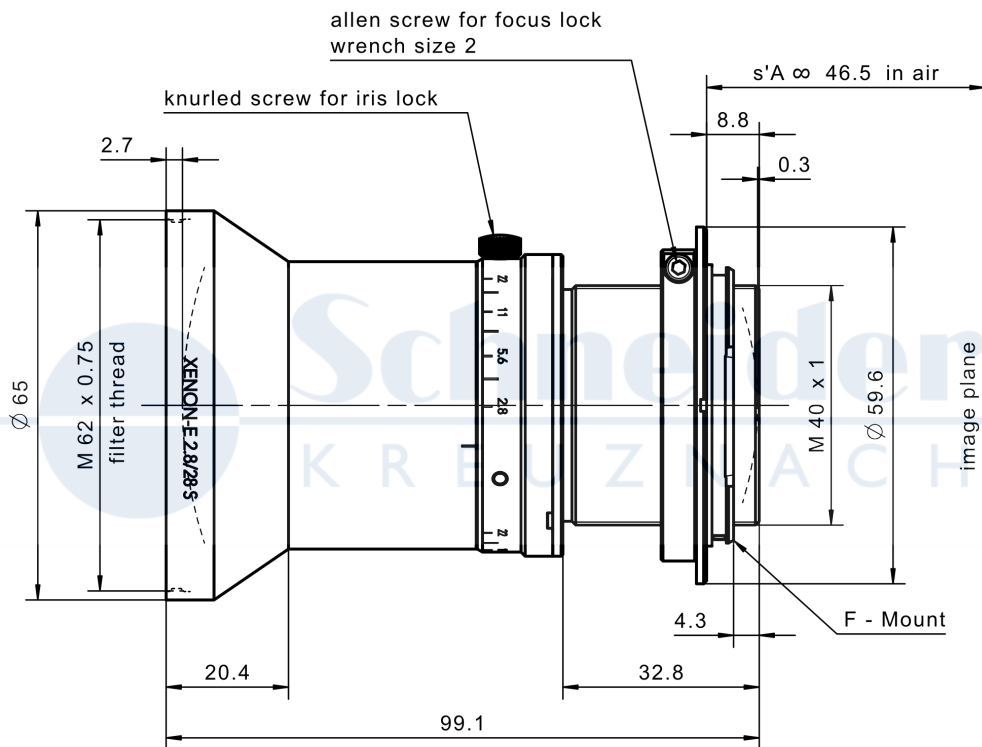

standard

Annotation	
Focal length	Nominal focal length
F/# range	Image space F-number range for infinity focus position
Numerical aperture	Maximum real numerical aperture (depending on recommended magnification range either for infinity or respective fixed magnification)
Max. sensor size	Image circle diameter
Max. angle of view	Angle of view associated with maximum sensor size (depending on recommended magnification range either for infinity or respective fixed magnification)
Rec. magnification range	Magnification range as recommended by Schneider-Kreuznach
Rec. working distance range	Working distance, i.e. distance between object and first mechanical element, associated with recommended magnification range
Max. mechanical focus travel	Maximum possible movement of the lens from infinity position (depending on recommended magnification range either for infinity or respective fixed magnification)
Net weight	weight of unpacked lens without lens cap
f'_{eff}	Effective focal length
SF	Distance between vertex of first lens surface and object space focal point
S'F'	Distance between vertex of last lens surface and image space focal point (back focal distance at infinity)
HH'	Distance between principal planes
$\beta'P$	Pupil magnification (= exit pupil diameter / entrance pupil diameter)
SEP	Distance between vertex of first lens surface and entrance pupil
S'AP	Distance between vertex of last lens surface and exit pupil
Σd	Distance between vertices of first and last lens surface
s'A	Flange focal distance (in air) for infinite object distance (depending on recommended magnification range either for infinity or respective fixed magnification)
β'	Magnification (= image size / object size), negative value because image is inverted
OO'	Distance between object and image

Unless otherwise stated all dimensions in this data sheet are in mm.