

Key Features

- Uses standard PC Ethernet port & hardware
- Supports cable lengths up to 100 m (CAT-5e or CAT-6)
- Simplified set-up with field proven Sopera Essential software featuring CamExpert
- Engineered to accommodate industrial environment with a Ruggedize, screw mount, RJ-45 connector
- Auto-Iris (Video, DC or Motorized)

Programmability

- Higher frame rates achievable in partial scan mode
- Global electronic shutter with exposure Control
- Auto-Brightness Feature
- Extended Dynamic Range Function
- On-board flat-field correction
- Multi-Exposure Feature
- Programmable LUTs
- On-board Image compression
- Transfer On-Demand Function
- IEEE1588 Precise time Protocol

Typical Applications

- Electronics manufacturing inspection
- Industrial metrology
- Intelligent traffic systems

Overview

Compact GigE Vision camera with uncompromised image quality.

The Genie TS-M4096 uses a Teledyne DALSA CMOS, monochrome sensor with a resolution of 4096x 3072. Teledyne DALSA's proprietary sensor technology allows for image capture rates of 10 fps in 12 megapixel resolution while maintaining exceptional image quality. The Genie TS-M4096 takes advantage of gigabit Ethernet technology, transmitting data over standard CAT-5e and CAT-6 cables to distances of up to 100 m. Like all Genie cameras, the TS-M4096 is based on AIA (Automated Imaging Association) GigE Vision Standard to directly link the camera to a PC.



Specifications

Active Resolution	4096 x 3072
Frame Rate	10 fps in Free-running / 12fps in Burst Mode
Pixel Size	6.0 μm
Data Format	8 and 10-bits
Exposure Control	Automatic, Programmable, or via External Trigger
Dynamic Range	60 dB
Gain Control	Automatic, Manual and One-Push Gain modes
Output	Gigabit Ethernet, also supports 100 Mbps
I/O Ports	4 opto-isolated input, 4 opto-isolated output, 3 motorized Control, RS-485 Port, and RS-232 Port
Lens Mount	M42 x1
Size	49 mm x 49 mm x 54 mm
Mass	TBD
Operating Temp	0°–50°C
Power Supply	12 to 24V or Power Over Ethernet (POE)
Power Dissipation	~4 to 5W
Data Connector	Standard or Screw mount RJ-45
Power and I/O	Micro-D 25-pin and 4-pin auto-Iris
Regulatory Compliance	FCC Class A, CE, RoHs 2002/95/EC (Pending)
Camera Specification	GigE Vision v2.0 Compliant (Pending)
Software Platform	Teledyne DALSA Sopera LT or 3rd Party Genicam Compliant SDK
Part Number	G2-GM10-T4095

Genie TS-M4096

Area Scan Monochrome Cameras

All Genie cameras feature value added functionality designed specifically for imaging and machine vision applications. All features are easily accessible with Teledyne DALSA's advanced software tools. These tools deliver superior image capture, performance, and control.

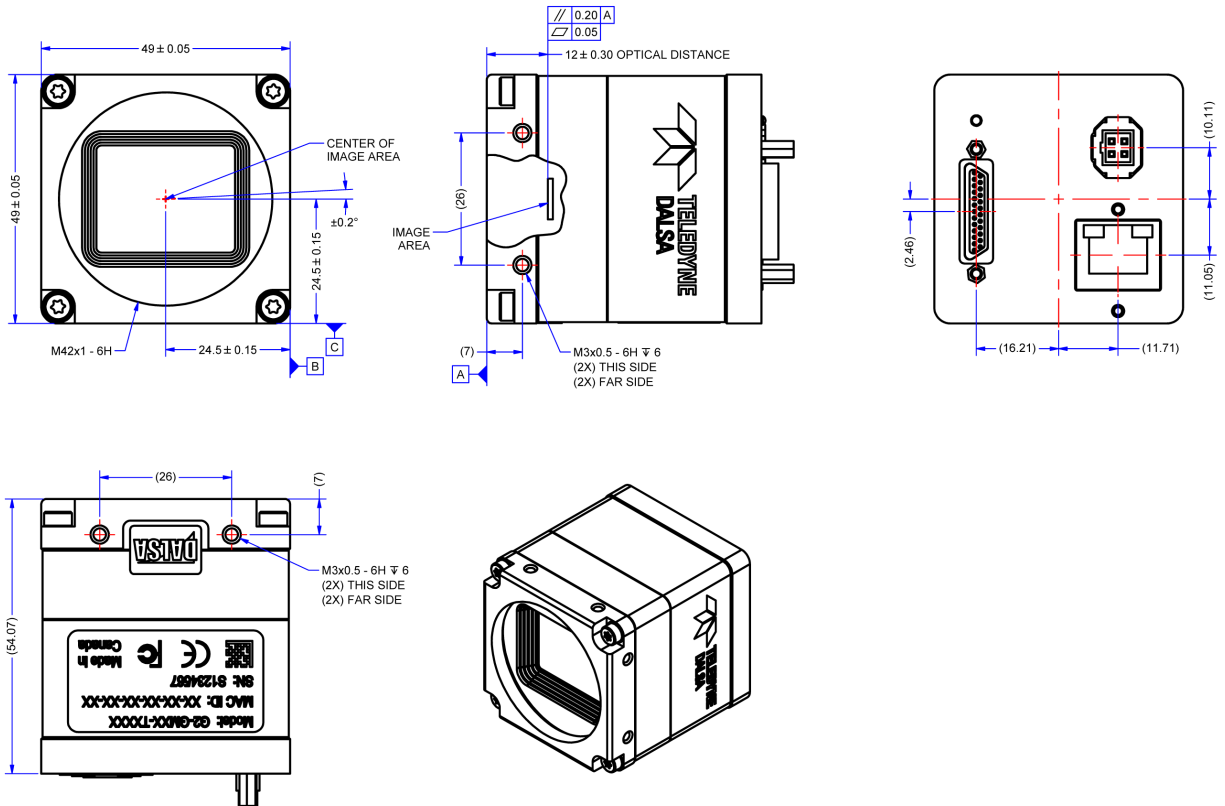
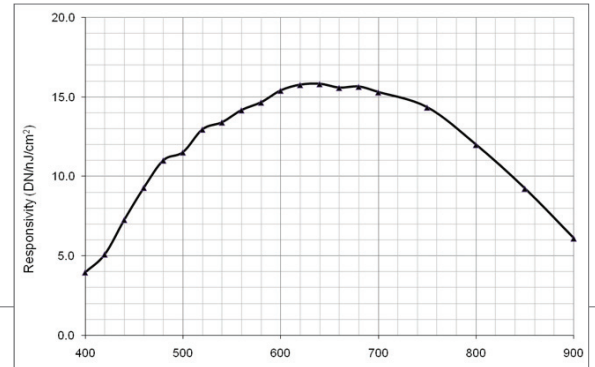

NOTES:
 1. UNITS: MILLIMETERS.
 2. IMAGE AREA IS ALIGNED TO DATUMS **A**, **B** & **C**

www.teledynedalsa.com

Americas

Boston, USA
 +1 978-670-2000
sales.americas@teledynedalsa.com

Europe

Munich, Germany
 +49 8142-46770
sales.europe@teledynedalsa.com

Asia Pacific

Tokyo, Japan
 +81 3-5960-6353
sales.asia@teledynedalsa.com

Shanghai, China
 +86 21-3368-0027
sales.asia@teledynedalsa.com

Teledyne DALSA has its corporate offices in Waterloo, Canada
 Teledyne DALSA reserves the right to make changes at any time without notice. Teledyne DALSA © 2011.

